

DIE ABBUNDPROFIS

Checkliste 2 Holzrahmenbau: **Wir sind Abbund.**

Kunde:
 BV:

Datum:
 Liefertermin:

Wandaufbau AW

Wall Top

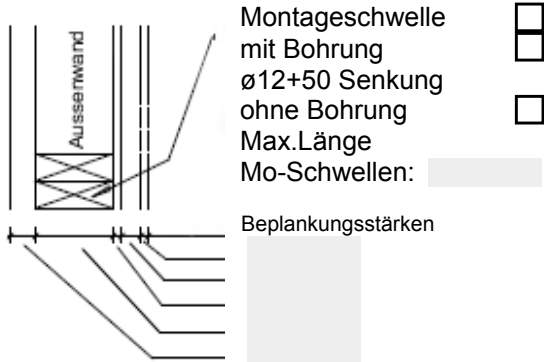

Wandaufbau IW

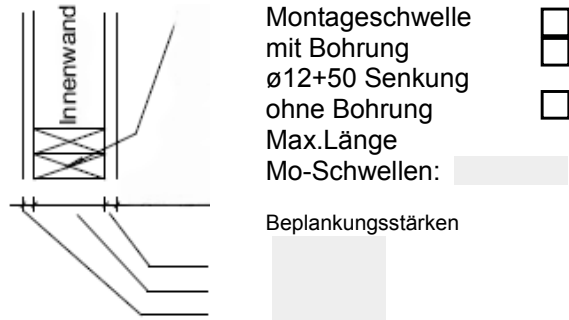

Aufbaukasten

Schalungsüberstand in Öffnung

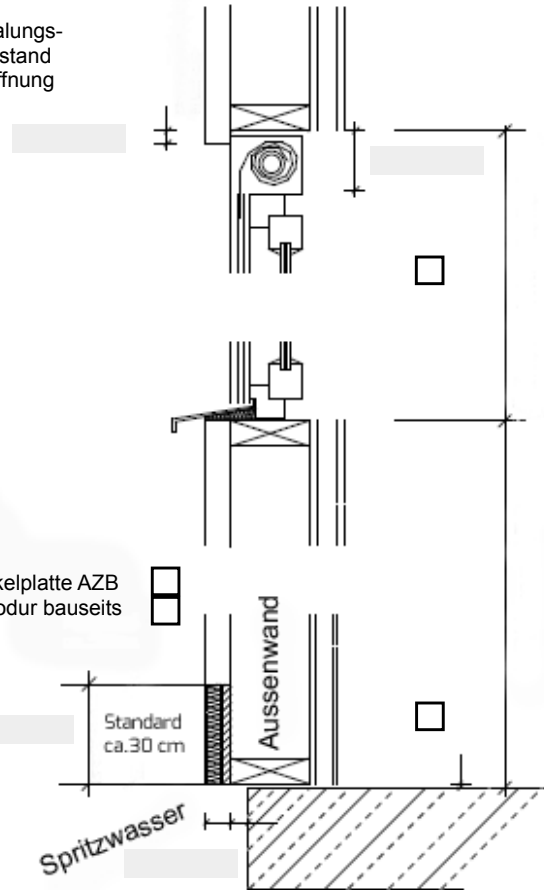

Kasten mit Putzträger

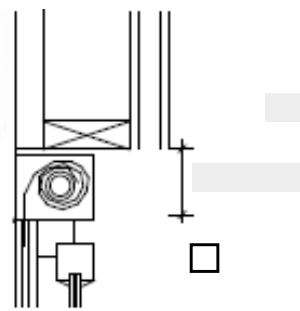

Vorbaukasten

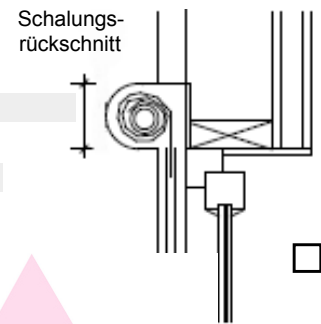

Rolladendetail nach Angabe des Fensterbauers

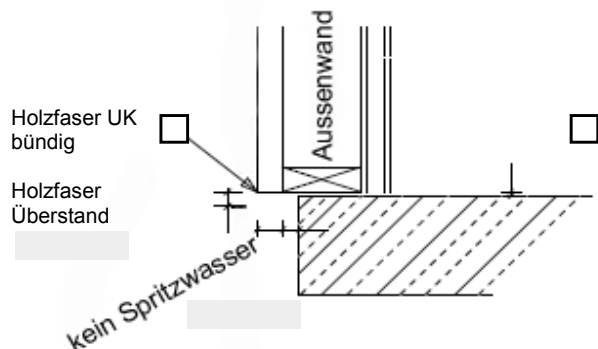

Fensteranschluss seitlich

